

Specialist Kerbs

Kassel Kerb

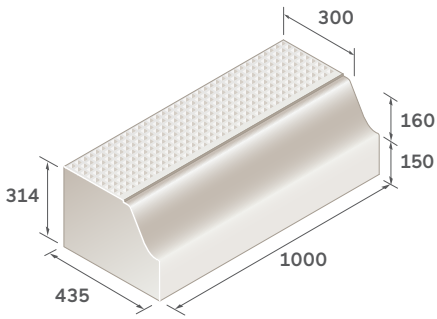

Standard Kerb 160mm

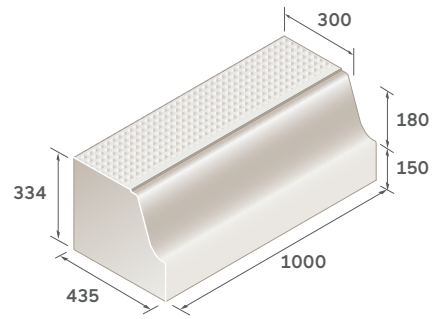

Standard Kerb 180mm

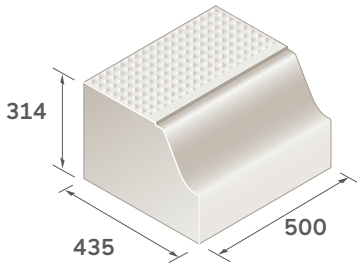

Half Kerb 160mm

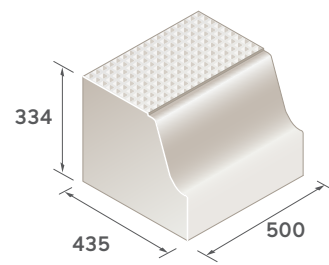

Half Kerb 180mm

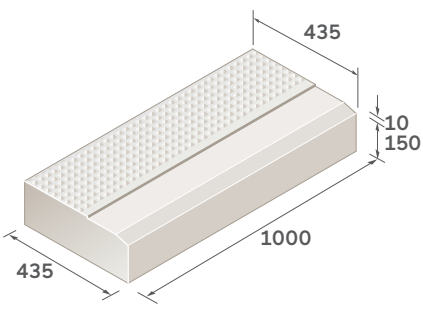

Flat Kerb

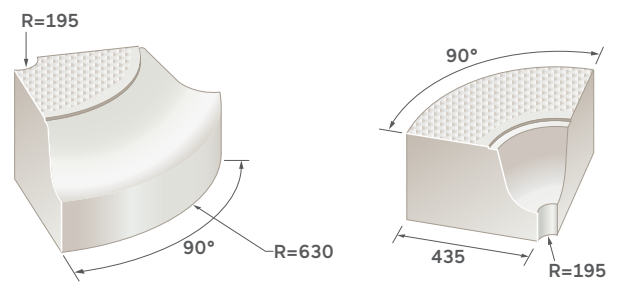

90° quadrant (external or internal)

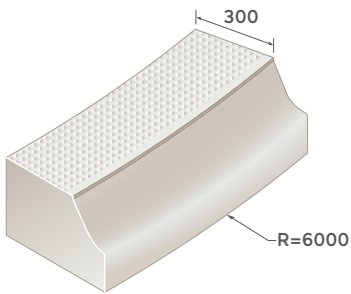

6m external radius

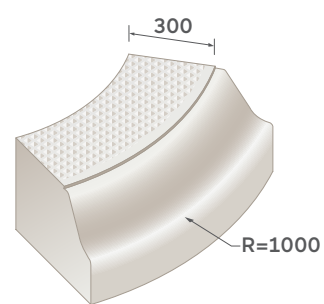

45° external quadrant

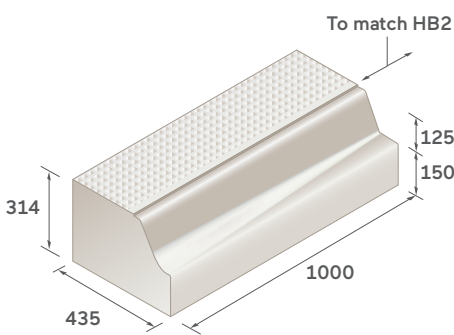

Left hand transition 160mm

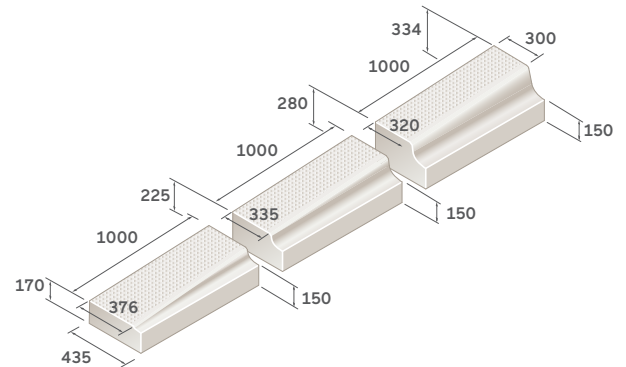

Right hand transition 180mm

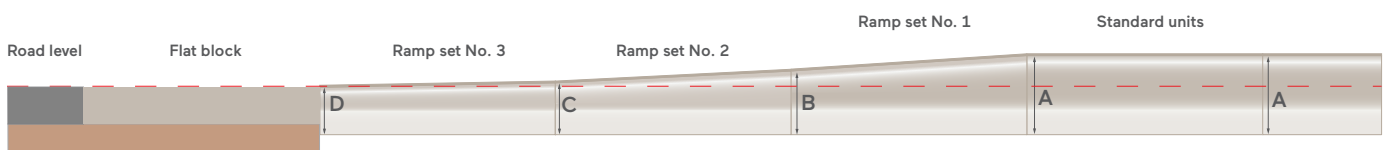

Front elevation - right hand ramp set